



Panel control box designed to ensure an easy installation

POSITION LIMIT SWITCH
PROGRESSIVE IGNITION MOTOR
POWER SUPPLY 230/24 VDC
PROGRAMMABLE CONTROLLER

CONTROLLER:

- CONVENIENT POSITION LIMIT SWITCH PROGRAMMING
- DISPLAY:
 - MOTION SETTING
 - MOTOR CONSUMPTION (AMPS)
 - SPEED
- WARNING NOTIFICATION
- SECURITY SAVES: NO VOLATILE MEMORY

Box:

- HARD SHAPE MADE
- LOW DIMENSIONS
- IP55
- EASY CABLING HARNESS
- SCREW FIXATION INCLUDED

TECHNICAL CHARACTERISTICS:

- ELECTRONIC PROTECTION OF THE MOTORISATION
- POWER SUPPLY 230 VAC - 50/60 Hz
- 24 VDC TRANSFORMER
- FUSE PROTECTION
- WORKING TEMPERATURE: +10°C À +40°C
- RELATIVE HYGROMETRY UP TO 80%

CONFORMITY NORMS:

- NFP 90-308
- EN 60335-1
- EMC

PANEL CONTROL BOX

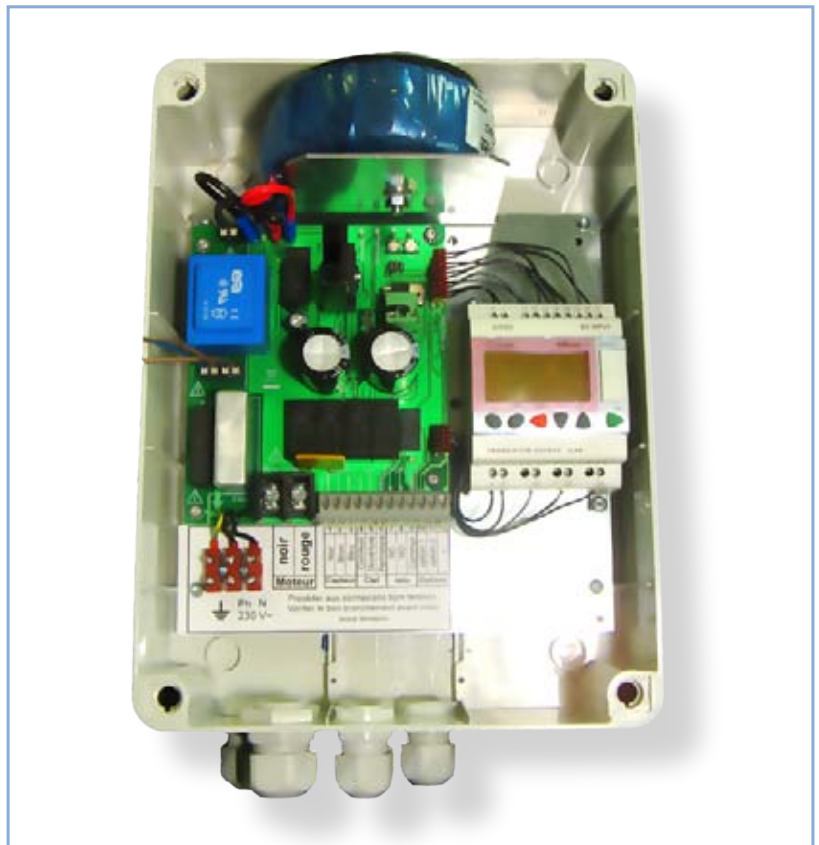

BOX DIMENSIONS

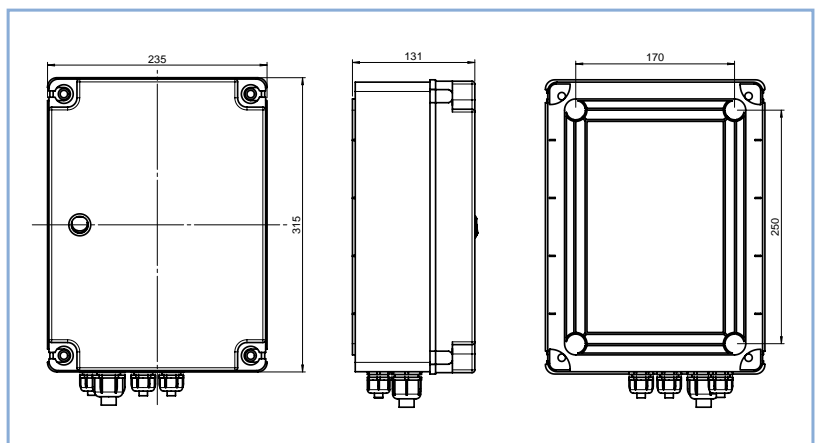

CHARACTERISTICS OF THE PANEL CONTROL BOX

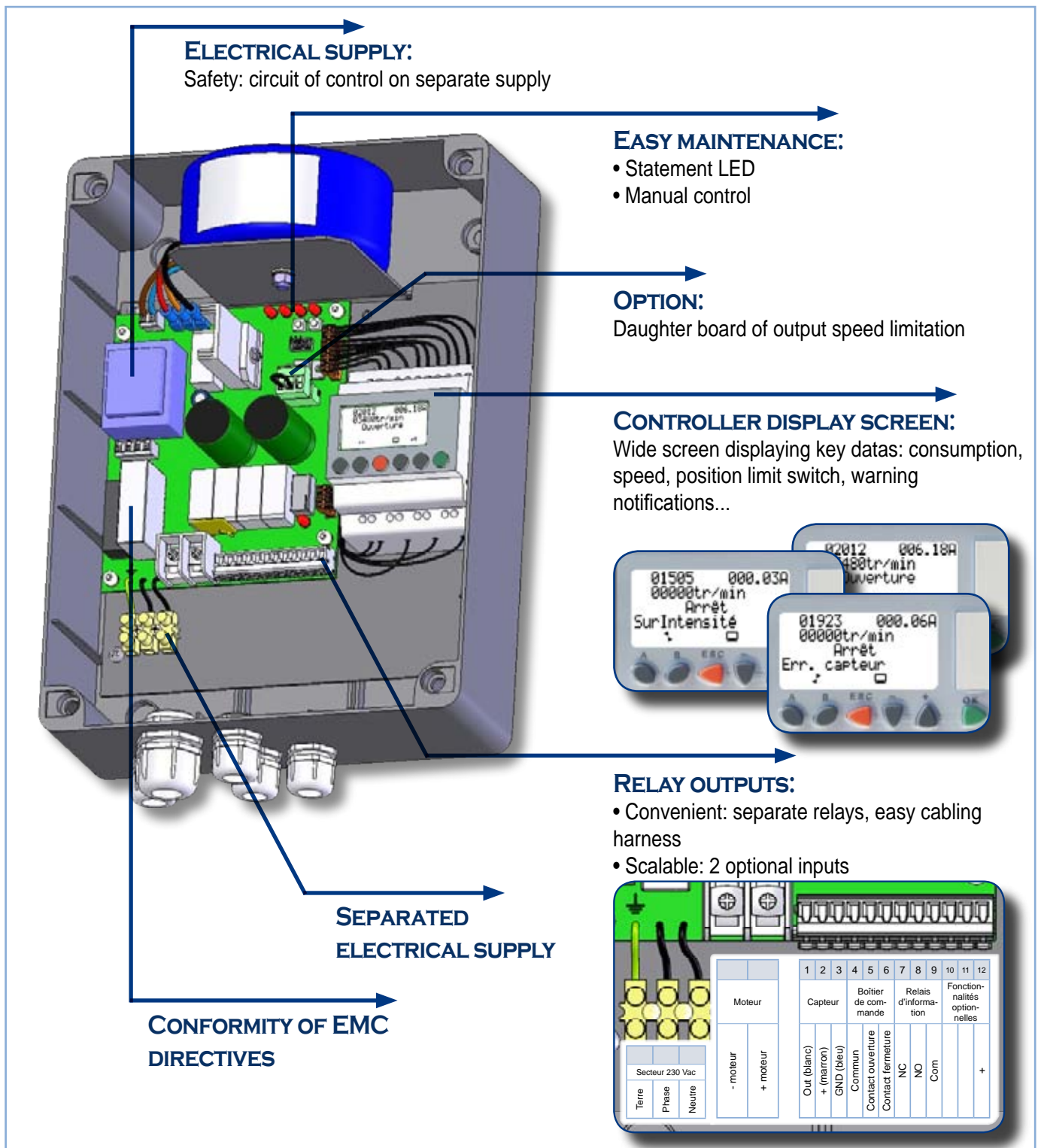

The box is specially designed to control immersed motorisation of automatic pool covers made by SIREM. A product norm is associate to the final product (cover pool with immersed motorisation in axis) therefore the installation of the box must be conform to NFP 90-308 instructions (in France).