

TYPE

RE.0444 N



DESTINATION

- Industrial applications

DISCRIPTION

- The most common DC tachometer
- Permanent magnet excitation
- Brush-holder under cover
- Cable connection
- Low ripple
- Available with one and two commutators

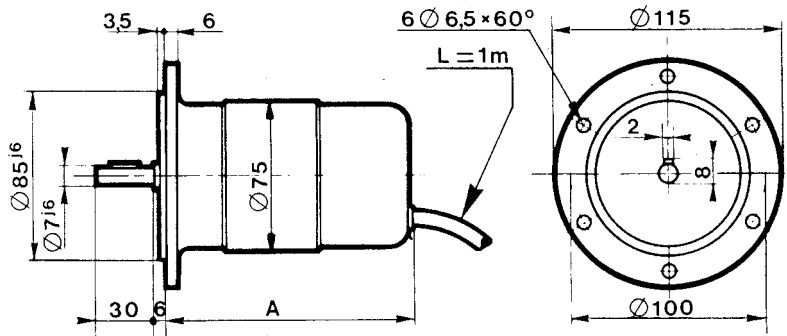

	1 collector	2 collector
A Ø 7	128	144
Ø 11	131	-
Ø 14	128	-
B Ø 7	134	150
Ø 11	137	-
Ø 14	141	-
C Ø 7	14,5	30,5
Ø 11	17,5	-
Ø 14	21,5	-
Weight kg	1,8	2,1

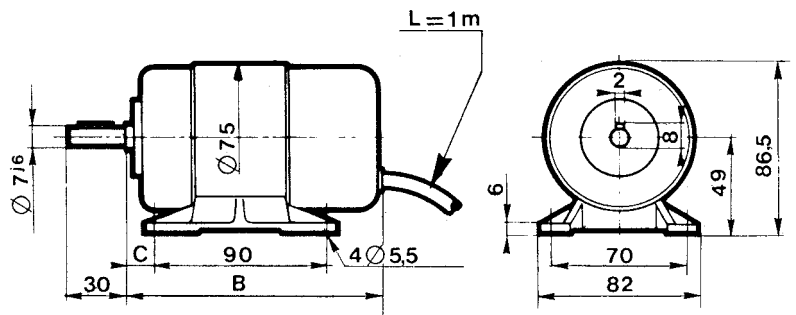

GENERAL DATA

Designation	Symbol	Unit	Value	
Maximum speed (mechanical)	n_m	rpm	12000	
Moment of inertia	J	kg cm ²	0,950	
No load driving torque	M_r	N. cm	1,5	
Maximum radial shaft stress	F	da N	0,4 Ø 7 mm	1,0 Ø 11 mm
Maximum E.M.F.	E_m	V	600	
Maximum linearity error	ΔE	% E_T	≤ 0,15	
Overall ripple rate (peak to peak)	ΔE_C	% E_C	≤ 0,5	
Rotation harmonics (f = 2 p. n.)	ΔE_P	% E_C	≤ 0,2	
Slot harmonics (f = Z. n.)	ΔE_Z	% E_C	≤ 0,3	
Calibration precision	ΔE_o	% E_{T_o}	± 1,0	
E.M.F. temperature drift - not compensated	ΔE_θ	% /°C	0,02	
- compensated			0,005	
Time constant	C_t	ms	2,5	
*Filter: Time constant	RF x CF	ms	0,47	
Load current	I_c	mA	5	
Speed	n	rpm	3000	

Construction details	
Number of poles	2
Number of armature slots	19
Number of collector blades	57
Insulation class	B (IEC 34-1)
Operating temperature	-30° - 130 °C
Climatic protection	C _a (IEC 68-1)
Protection degree	IP 44 (IEC 34-5)
Direction of rotation	Reversible
Excitation	Permanent magnets Alnico

* Filter-connecting diagram on demand

Rev.: 02

We reserve the right to modify technical features in the interest of technical advance.

DESTINATION

- Industrial applications

DISCRIPTION

- The most common DC tachometer
- Permanent magnet excitation
- Brush-holder under cover
- Cable connection
- Low ripple
- Available with one and two commutators

TYPE
RE.0444 N

Mechanical options

Shaft ends and bearings

	Mounting side				Opposite mounting side		
	D (mm) N1	N2	L (mm)	Bearings	D (mm)	L (mm)	Bearings
Standard	7 / 11	7	30	8 x 22 x 7 ZZ / 12 x 28 x 8 ZZ	7	30	8 x 22 x 7 ZZ
Max.	14	8	-	15 x 35 x 11 ZZ	8	-	8 x 22 x 7 ZZ

Options

- Sealing cover (IP 55), flange model
- Special flange
- Terminals under cover plate
- Lateral cable connection

Markings and polarity of terminals (cables) for counter-clockwise rotation viewing the mounting face

		A1 : +	A2 : -
1 collector			
2 collectors	1. collector	1A1: +	1A2: -
	2. collector	2A1: +	2A2: -

Available options on 2nd shaft end

- second flange

Electrical options

				Min.										Max.
E.M.K. at 1000 rpm.	E_n	V	1 coll. 2 coll.	6	20 2 x 20	30 2 x 30	40 2 x 40	50 2 x 50	60 2 x 60	80	100 2 x 100	120	150	200
Voltage gradient	C_v	V/rpm	1 coll. 2 coll.	0,006	0,020 2 x 0,02	0,030 2 x 0,03	0,040	0,050 2 x 0,05	0,060 2 x 0,06	0,080	0,100 2 x 0,1	0,120	0,150	0,200
Armature resistance	R_a	Ω	1 coll. 2 coll.	1,50	12 2 x 24	28 2 x 55	45	70 2 x 150	100 2 x 200	180	280 2 x 470	400	640	900
Max. thermal load	I_{th}	A	1 coll. 2 coll.	1,40	0,55 2 x 0,23	0,35 2 x 0,14	0,25	0,22 2 x 0,09	0,18 2 x 0,09	0,14	0,11 2 x 0,05	0,09	0,07	0,07
Max. allowed speed	n_a	Rpm	1 coll. 2 coll.	12000	12000 12000	12000 12000	12000	12000 12000	10000 10000	7500	6000 6000	5000	4000	3000

Brushes

Number	Size	Grade	Application limits	Reference
4 or 8	3,1 x 4,1 x 12,5	Electro graphite (EG)	STANDARD Max. output voltage 600 V	31 - 41 - EG
		Silver-graphite (CA)	Recommended for low speed and E.M.F. < 300 V	31 - 41 - CA

Rev.:02

We reserve the right to modify technical features in the interest of technical advance.